

LENNOX REAL

Real Comfort, Real Connection, Real Control.



LENNOX REAL

208/230 – 1 phase

R-410A

1.5 Ton (max 3 IDUs)
2 Ton (max 4 IDUs)
3 Ton Single Fan (max 5 IDUs)
3 Ton Dual Fan (max 5 IDUs)
4 Ton (max 7 IDUs)
5 Ton (max 9 IDUs)

Same IDU selection as Standard VRF

Can be used with conventional IDUs

Cooling operating temp: 5F to 118F
Heating operating temp: -13F to 70F



1.5, 2 and 3 Ton



3, 4 and 5 Ton

Available June 2023



NEW Wall Mount Air Handler

Non VRF - 24 V Controls



Sizes: 1.5, 2, 2.5, 3 Ton

Features

- Direct-drive, multi-speed motors allow air volume variation for heating / cooling.
- Multi-speed ECM motor
- Thermoplastic drain pan with bottom primary and secondary drain connections.
- Built in filter rack
- Wall-hanging bracket provided.
- Front or bottom return available.
- Optional heating elements of 5kW, 8kW, and 10kW.
- All aluminum coil



NEW Wall Mount Air Handler

Non VRF - 24 V Controls



DIMENSIONS

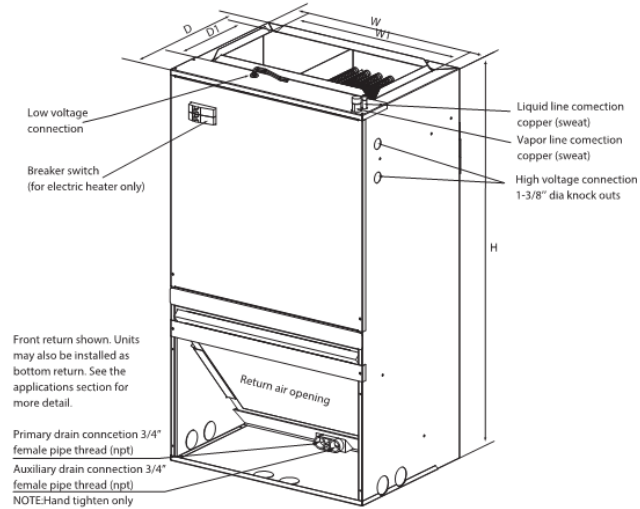

Dimensional Data

Model SIZE	Height 'H' (in. [mm])	Width 'W' (in. [mm])	Width 'W1' (in. [mm])	Length 'D' (in. [mm])	Length 'D1' (in. [mm])
18/24	36-1/2 [928]	20-1/2 [522]	17-2/5 [422]	15 [381]	9-1/2 [242]
30/36	39-1/2 [1,003]	22-13/16 [554]	18-3/4 [477]	19 [482]	9-1/2 [242]



Unique one to one connection – any furnace + coil / air handler

- Direct connection to conventional indoor units
- Use of any 24V thermostat

2023 Lennox REAL

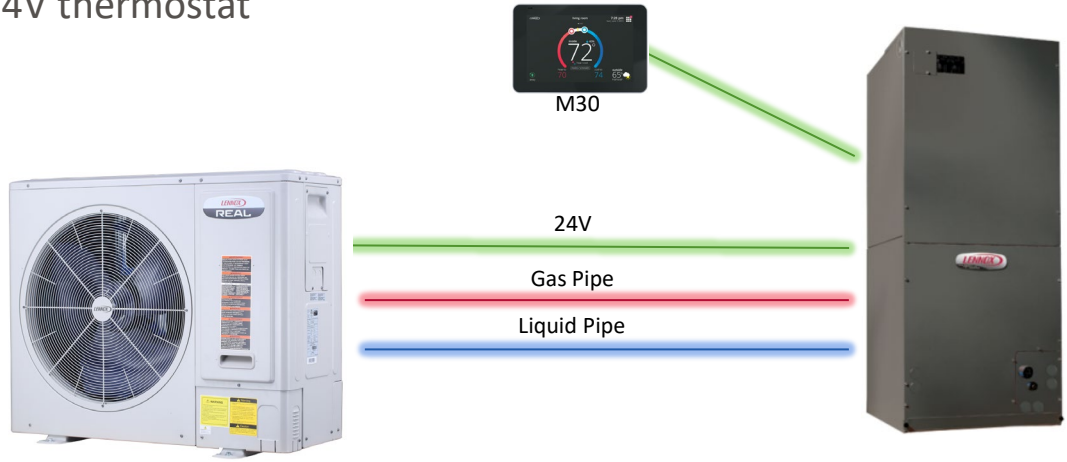

- Wires among ODU, IDU, KIT
- Wires among Controller, IDU, KIT
- Wires among 3rd party controller, KIT, coil, AHU



Connect to a VRF IDU & conventional air handler

- Connect to multiple air handlers, furnaces, coils
- Separate AHU kits required to control IDUs separately

2023 Lennox REAL

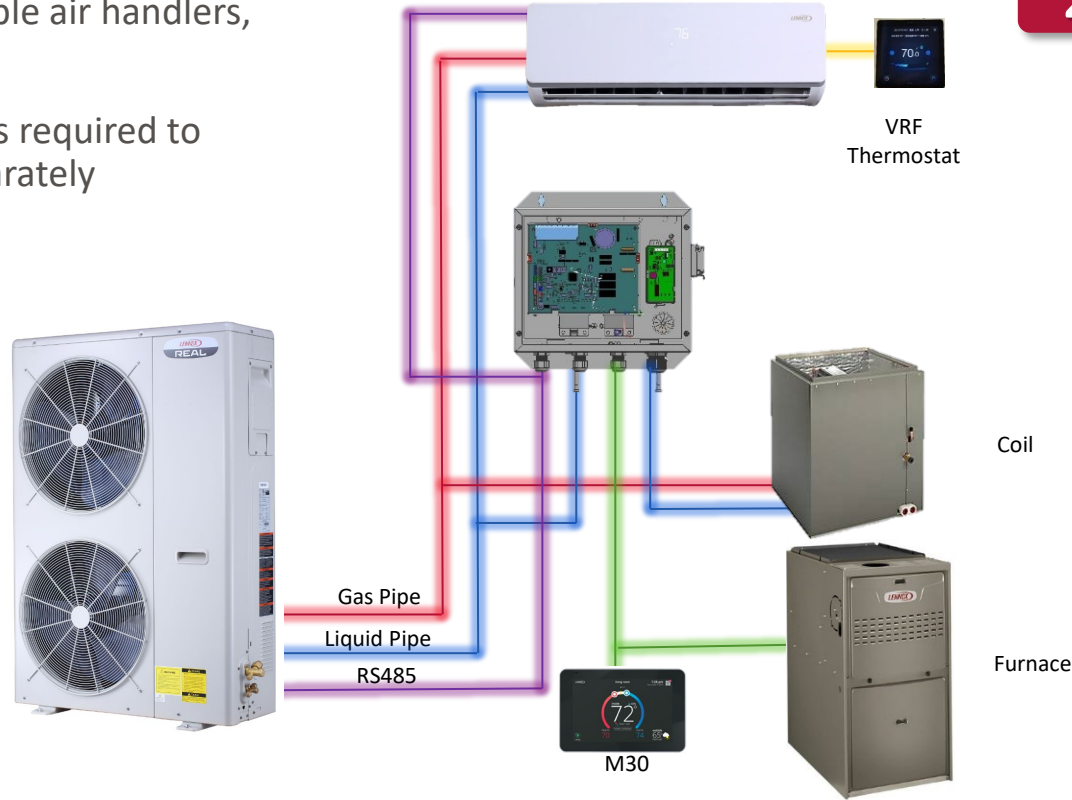

Wires among 3rd party controller, KIT, coil, AHU

Wires among Controller, IDU, KIT

Wires among ODU, IDU, KIT



Improved Multi Unit Application

- Connect to multiple air handlers, furnaces, coils
- Separate AHU kits required to control IDUs separately

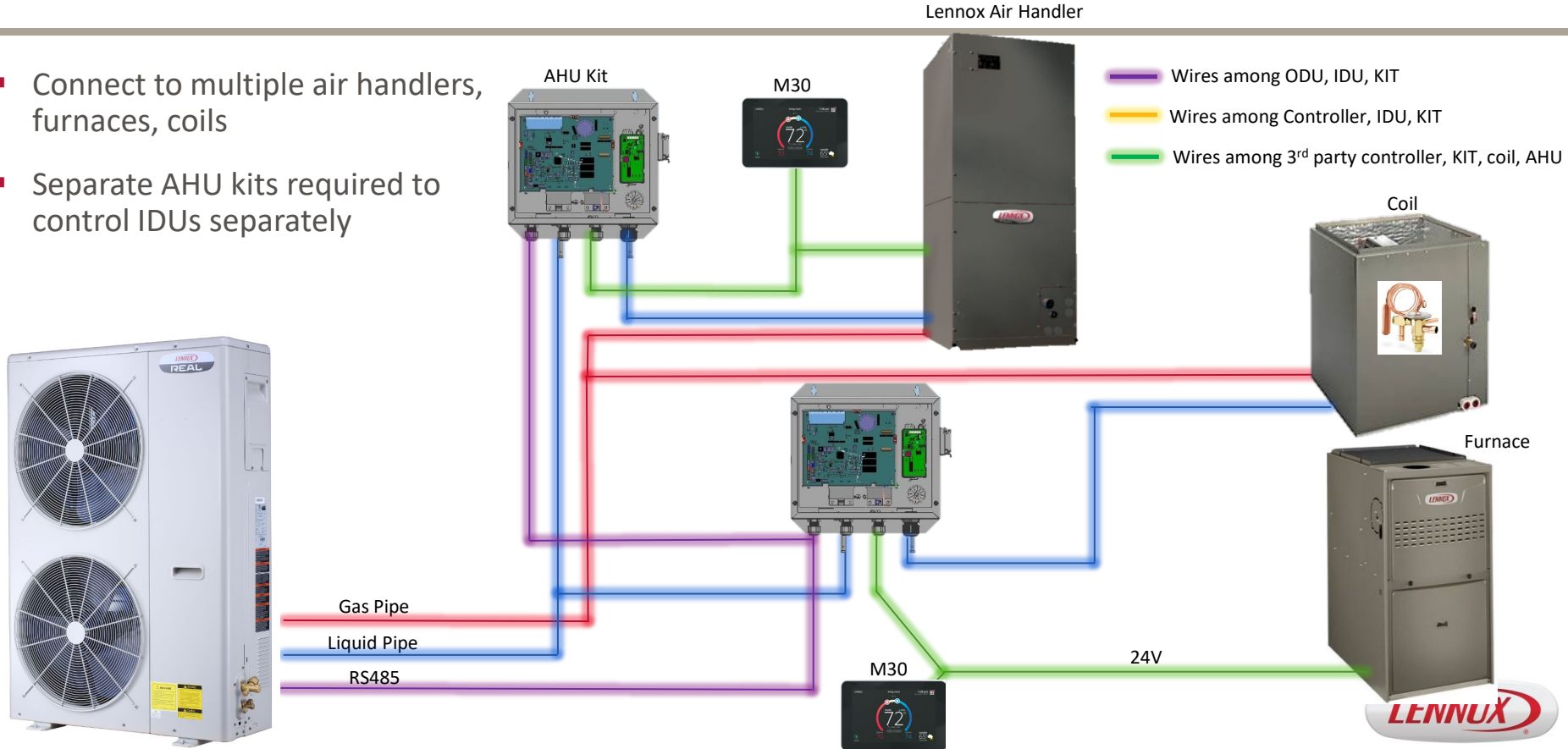

Features	Daikin FIT	Lennox REAL
Voltage /Phase	208-230V/1 Ph	208-230V/1 Ph
Refrigerant	R-410A	R-410A
Capacity Range	1.5 – 5 Tons Single Fan Heat Pump	1.5 – 3 Tons Single Fan Heat Pump 3 – 5 Tons Dual Fan Heat Pump
Efficiency	Up to... 18 SEER 10 HSPF	Up to... 19 SEER 11.5 HSPF
Compatible Indoor Units	<ul style="list-style-type: none"> Vertical air handlers Gas furnaces Coils 	<ul style="list-style-type: none"> VRF Indoor Units (ducted/ductless) Non VRF vertical air handlers Gas furnaces with loose coils Front return vertical air handler Pancake horizontal air handler
Max # of Indoor Units	One	Single or Multi-Zone (Up to 9 Indoor Units)
Sound Levels (dBA)	As low as 56 dB(A)	As low as 40 dB(A)
Heating Operating Range	-10°F to 70°F	-13°F to 70°F
Cooling Operating Range	0°F to 115°F	5°F to 118°F
Dimensions (W X D X H)	1.5 - 3 Ton – (36.6 X 13.8 X 27.4) 3.5 - 5 Ton – (37 X 12.6 X 39)	1.5 - 3 Ton – (41 X 16 X 34) 3.5 - 5 Ton – (38 X 13 X 52)
Controls	Daikin ONE + Smart Thermostat	Can be used with any thermostat such as Nest or Lennox M30, E30 or Lennox VRF thermostats